



Tetra Tech

**TETRA TECH CO. LTD.**

**شركة التقنية الثلاثية**

Process Engineering & Equipments  
for Dairy, Beverages, Water, Food,  
Confectioneries, Chemical, Cosmetics,  
Pharmaceutical Industries



[www.tetrattech.com.sa](http://www.tetrattech.com.sa)

## ABOUT US

Tetra Tech was emerged in industrial horizon of Kingdom of Saudi Arabia in Year 2003 with “One Window Service” concept. Today, Tetra Tech is a leading industrial services company covering Middle East, Africa & Asian countries in the field of Process Engineering, Project Management, Industrial Automation, Electrical, Instrumentation and Control, HVAC Solutions, Turn Key Solutions provider for small, medium and large scale projects in Dairy, Food & Beverages, Fertilizer, Packaging, Printing, Pharmaceutical, Personal Care, Cement, Plastics, Oil & Gas, Construction, Chemical and Automobile Industries.

Tetra Tech offers “One-Window Service” with a creative approach, engineering expertise, multiple technical resources and a problem-solving attitude as your partners in the industry. Tetra Tech products, solutions and services are inevitable for the success of its esteemed customers.



## MISSION

Our aim is to have loyal and happy employees whose ultimate job is to have satisfied customers & contribute to the betterment of society & nature as a whole and to be profitable.



## VISION

Tetra Tech is committed to provide customized, state of art and cost effective products and engineering services to its valued customers.



## SCOPE OF WORK

- Instrumentation & control, Electrical and Industrial Automation.
- Heat Ventilation Air Conditioning Systems.
- Industrial Refrigeration Systems.
- Manufacturing of various type of Tanks like CIP Tanks, Storage Tanks, Stainless Steel Silos, Process Tanks, Aging Tanks etc.
- Pasteurizes and Mixing Systems.
- Pumps, Heat Exchangers and Cooling Systems.
- Installation Material and Spare Parts.
- Complete Solution for Filling and Packaging Line Systems.
- Project Design, Engineering and Management Services.
- Water Treatment Plants and Sewage Treatment Plants.
- Cleaning and Filtration Systems.
- Handling projects on EPC and turnkey basis



We are leaders in our business with strong affiliations with companies. We provide

**“ONE WINDOW TOTAL SERVICES CONCEPT”**

## INSTALLATION MATERIALS & STOCKS

Keeping 14 Millions USD Installation Materials Stocks Consist of:

S.S. Pipes & Fittings - Valves - Pumps - Sheets - Flanges - Square Tubes - Food Grade Hoses - Filters - Tanks Accessories and related installation Materials of Dairy, Beverages, Water, Food Processing, Confectionary, Chemical, Cosmetics & Pharma Industries.

## TETRA TECH - TECHNICAL DIVISIONS

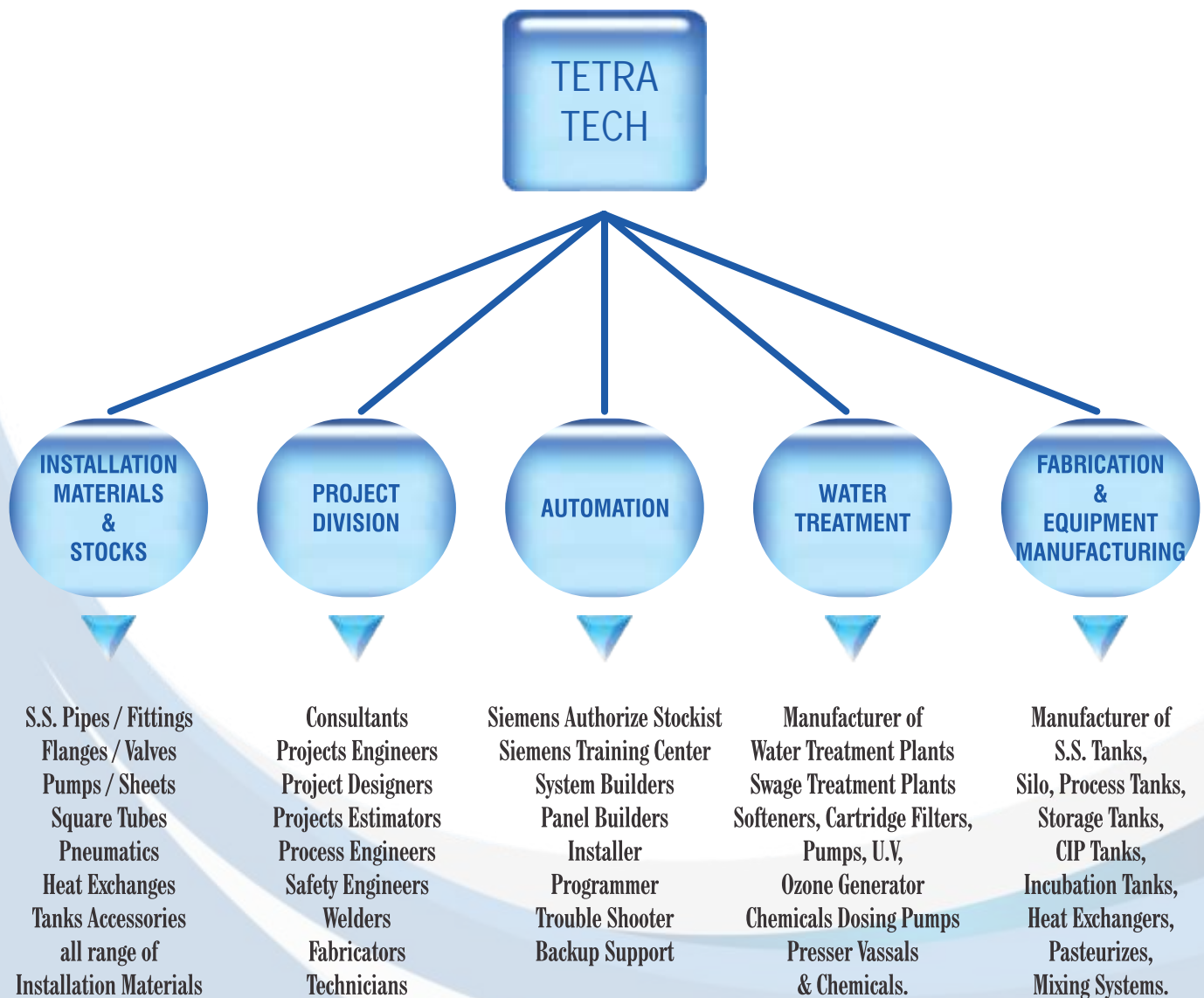

## TETRA TECH - PROJECT DIVISION

Tetra Tech have 270 highly qualified experts from multi-nationals professionals & engineers which comprised in \* Consultants \* Project Managers \* Project Engineers \* Project Designers \* Project Estimators \* Process Engineers \* Safety Engineers \* Authorised / Certified Welders from Al Hoty \* Fabricators \* Electromechanical Technicians & other relates staff.

## TETRA TECH - AUTOMATION DIVISION

Tetra Tech have complete range of solutions and installations for process industry automation and have specialized team with \* Consultants \* Project Engineers \* Technicians \* Panel Builders \* Programmers.

Tetra Tech is and authorised Siemens \* Training Center \* System Builders \* Stock Seller \* Installers \* Troubleshooter \* Programmer and backup support system provider.

## TETRA TECH - HEALTH & SAFETY POLICY

All Tetra Tech operation will be carried out so as to protect the health and safety of employees, sub-contractors, customers, the community and the environment.

We will pursue this policy through strategies and action plans developed as part of the Tetra Tech Safety program, visible management commitment and through the individual contribution of all employees, supported by education and training. Hazard analysis will be conducted and risk controls put in place.

All Managers, supervisors and contractors are accountable for health and safety performance in their areas. The company has a Rehabilitation policy and will help injured persons return to moral work as soon as possible.

Attitudes to health and safety are as important as other business qualities, and will be assessed regularly as part of the annual performance appraisal.



## OUR BRANDS

We are authorized distributor and channel partners of following Principal's.



**Alfa Laval** is a Sweden based, world leader company, within the key technology Areas of heat transfer, separation and fluid handling. Covering following Products Heat Exchanger; Agitators; Tank cleaning equipments; Oil / Gas Steam Boilers and Heater; Air, Gas and Liquid Cooler; Flow, Level, Pressure and Temperature Instruments; Filter and Strainers; Storage Tanks; Cooling Systems; Centrifugal Separators; Evaporation Systems; Brewery Solutions; Decanters; Pumps; Refrigeration Solutions; Safety Solutions, Pipes, Tubes and Fittings.

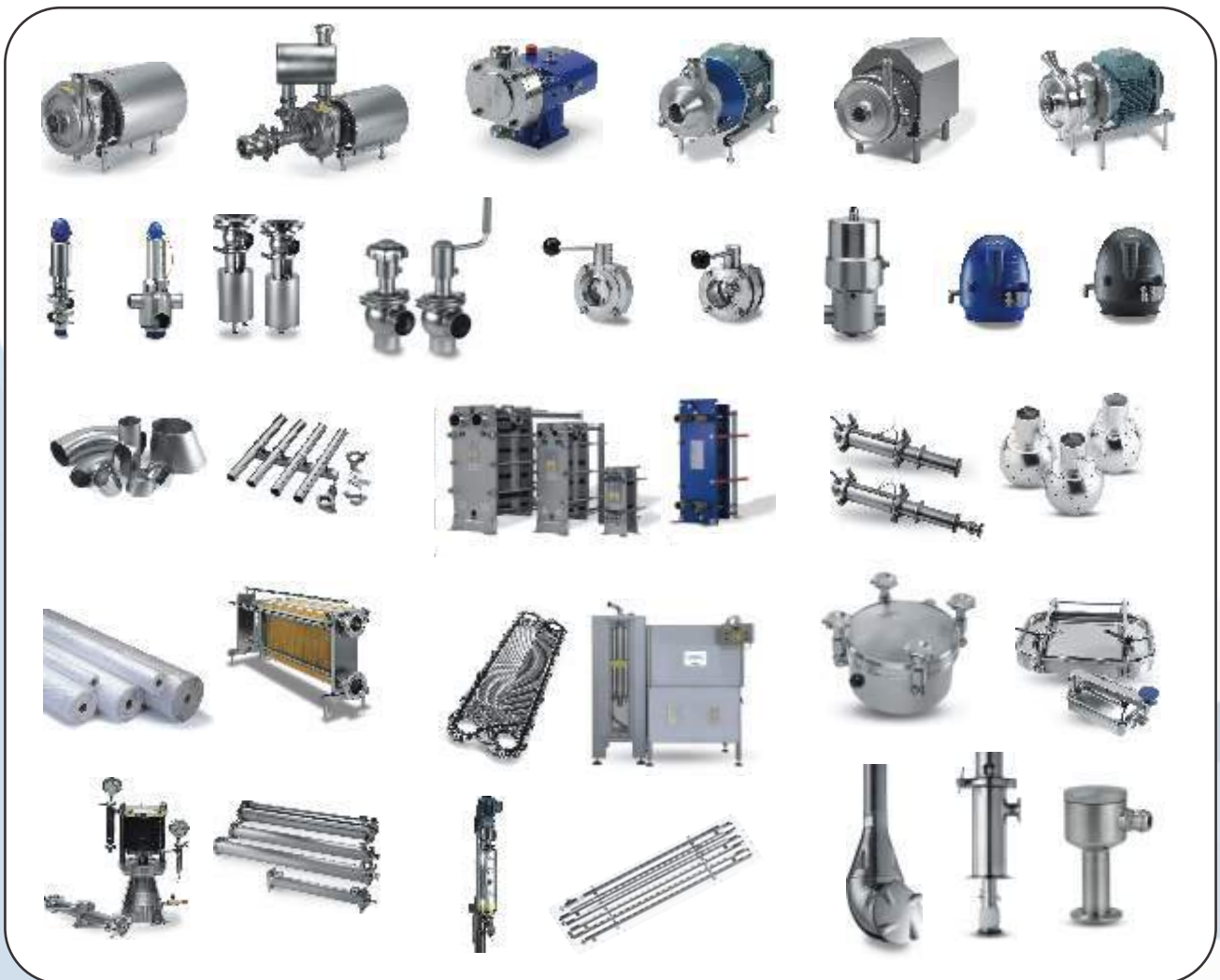



**AirTAC** International Group with its headquarter located in Taiwan. A well-known Supplier and manufacturer of pneumatic equipments in world market. AirTAC is specialized in producing actuators, control components, air preparation products, and accessories. (Solenoid Valves, Flow Control Valves, Pneumatic Control Valves, Manually and Mechanically Actuated Valves and Other Valves, Cylinders and their accessories.)



# BINGSHAN

PROFESSIONAL REFRIGERATION

**BINGSHAN** is a leading industrial refrigeration products manufacturer, which are mostly used in fruits, vegetables, meat and poultry, sea foods, beverages, processing freezing and refrigerating industries. Screw and Reciprocating type compressors, Condensers, Evaporators, Quick Freezers, Ammonia Circulated Vessel Package, Pre-fabricated cold storage, Ice making units, Smart systems, As well as customized energy optimization and sustainable cold chain solutions.







WIKAI is a global market leader in pressure, temperature and level measurement technology. WIKAI Provides Miniature resistance thermometer; Electronic pressure switch with Display; Pressure transmitters; Diaphragm monitoring system; Calibration bath; Bourdon tube pressure gauge; Bimetallic thermometer with switch contact; Digital Pressure gauges; Optoelectronics level switches; Level sensors; Reed sensors.





**Donaldson** is a USA based company, a leading filtration solutions provider. covering following products; Filter Elements and Housings for Compressed Air / Gas, Liquids and Steam applications; Sterile air units; Breathing air system; Aftercoolers; Condensate management system; Oil water separators; Drains; Powercore filter packs; Fume, Mist, Cyclon, Cartridge Collectors, Filter kits & carts; Membrane filters, Lube filters; Portable filter integrity test unit; Filters efficiency tester; Fluid analysis kit; Replacement filter and Accessories.





**Uzermak** a leading Turkish Company, It provides Process cheese machinery, kashkaval & mozzarella processing lines, pasta filata processing lines, cream cheese processing machines, mayonnaise & ketchup processing machine, cheese vats, filter drums, cooker & cooler & mixer machines, fetacut mechanical homogenizers, moulding machines, stretching machines, trolleys, centrifugal pumps, lobe pumps, curd feeding conveyors & filters, falling film evaporators, storage tanks, CIP tank & units, cooking vats and perforated vats.





**OPACK** Machine located in Turkey, It provides services and consultation about thermoform packaging machine, tray sealer machine, cap design prototypes and manufacturing for any kind of product's packaging systems. Also manufacture turnkey modular moulding systems for any kind of packaging machine. Opack provides special solutions for industrial automation and also support the packaging industry with their research and development studies.





**MILKOTEK-HOMMAK** is a Turkey based company. It provide products for Dairy, Food & Beverage, Chemical & Petrochemical, Cosmetic, Pharmaceutical, and Biotechnology industries. MILKOTEK-HOMMAK provides single stage and double stage homogenizers, Piston Pumps, Yogurt Filling Machines, Yeast and culture filling machines, Curd Cheese process machines and Ricotta Systems.





Keofitt A/S is a Danish company established in 1980 by master brewer Kai Ottung. Kai Ottung worked as master brewer around the world and assisted many breweries in developing their techniques.

In the process he also developed a unique product range for sterile sampling for the medical, the soft drink and the food industries as well as, of course, for his colleagues in the breweries around the globe





**Endülüs Krom**, Turkey. It provides specially designed plants of various diameters and stainless steel in quality, food and chemical process tanks i.e. Olive oil tanks, Milk process tanks, Stainless honey and molasses tanks, and various kind of storage, mixer , insulation, heating-cooling jacket, on-board transportation, filtration systems, turnkey food and chemical plants, installation of piping and automation systems.





Pastor Machine has 20 years experience in milk sector and realized many completed projects in milk industry.

Producing machine provide plate heat exchangers and full automatic controlled plate pasteurization systems for the first time in Turkey.

The main philosophy Pastor Machine is to determine the basic requirements of the investors with realistic view, to provide equipment assembly, personnel education, reception services after sale services, spare parts procurement, urgent interference opportunities.





## OUR BRANDS



## OUR MAJOR CLIENTS



## FABRICATION DIVISION

The philosophy of **TETRA TECH** is firmly rooted in our desire to excel and give our clients the most professional services available. Our expertise has been refined and honored to perfection over the years and have spurred the development of several groups of Companies, which add to our competitiveness. Since more actives are handled in house going by our envious track records and our ever-growing list of precious and satisfied clients, we are confident you will also choose us to source any services and solutions in our field of expertise because” we deliver, no matter what” All solutions are at one window.

We ensured our services and quality of work through professional, experienced and well trained staff, complying with international standards and innovative pattern.

We Endeavor to continually improve process, product and services with special emphasis on quality, safety and customer services.

We get the job done first time, in the most timely and cost effective approach, in the fields of Project Management, Installation, Commissioning and process Engineering Services.

Our Primary focus being centered on the optimization of manufacturing operations with Dairy, Beverages, Water, Food, Pharmaceuticals, and Chemicals & Cosmetics industries.

Our success is based upon the policy of utilizing our skills to complement, those of our clients management team.



## QUALITY & SAFETY

- **TETRA TECH** vision on this sector is a firm belief in Quality, safety, with high regards by implementing strictly on;
- Following up the safety procedures during Installation and Operation.
- Inducting Traceability and Operational Accountability in process design.
- Quality certification of materials used, according
- Knowledge full craftsmanship of the specific demands of industry.
- Collaboration with only ISO Certified world class companies.
- Addressing Good Manufacturing Practices, Design Qualification, Installation, Qualification, Operation Qualification and Process Qualification needed by Industry.
- Implementing Safety Hazard Control procedures according to HACCP.
- Regular specific training of our staff.
- Always keeping certified Welding, Fabricating staffs, who keeps the hygiene level high during installation.



# DESIGNING

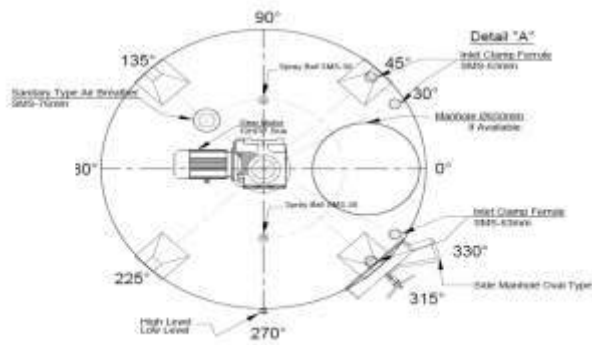
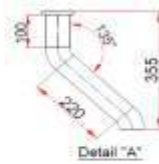
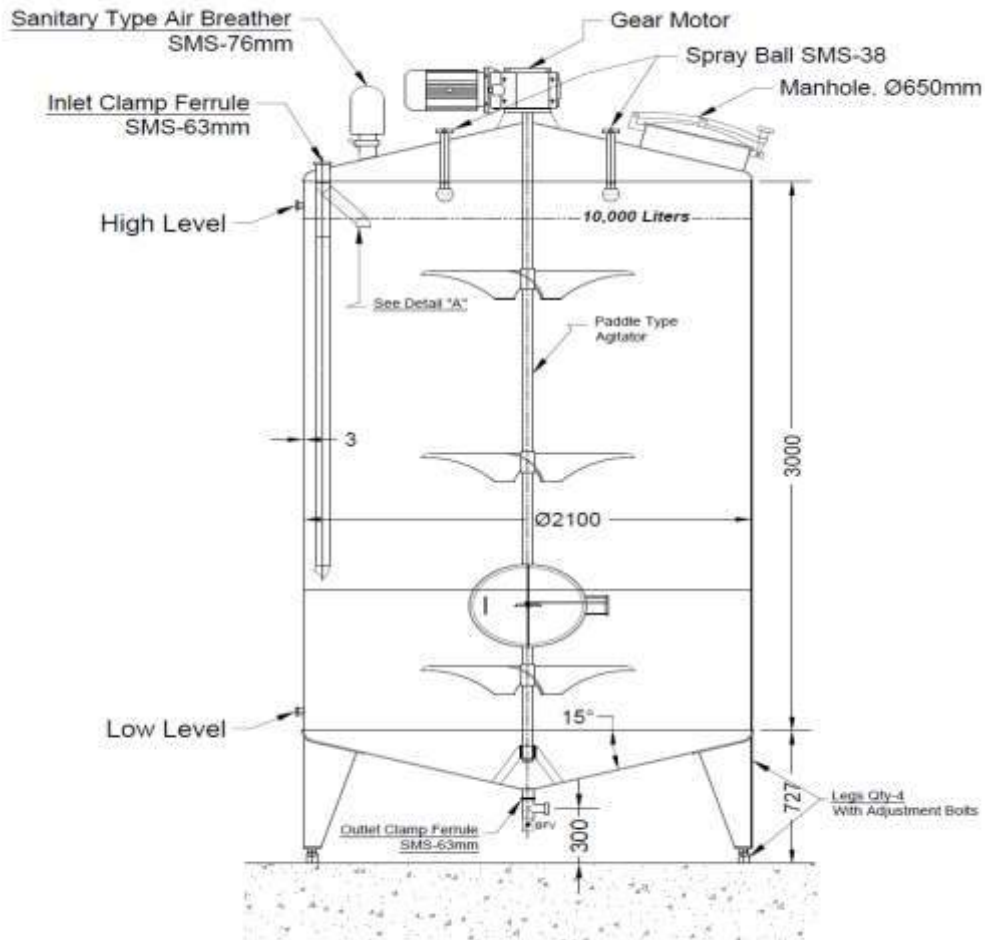

# CIP SYSTEM

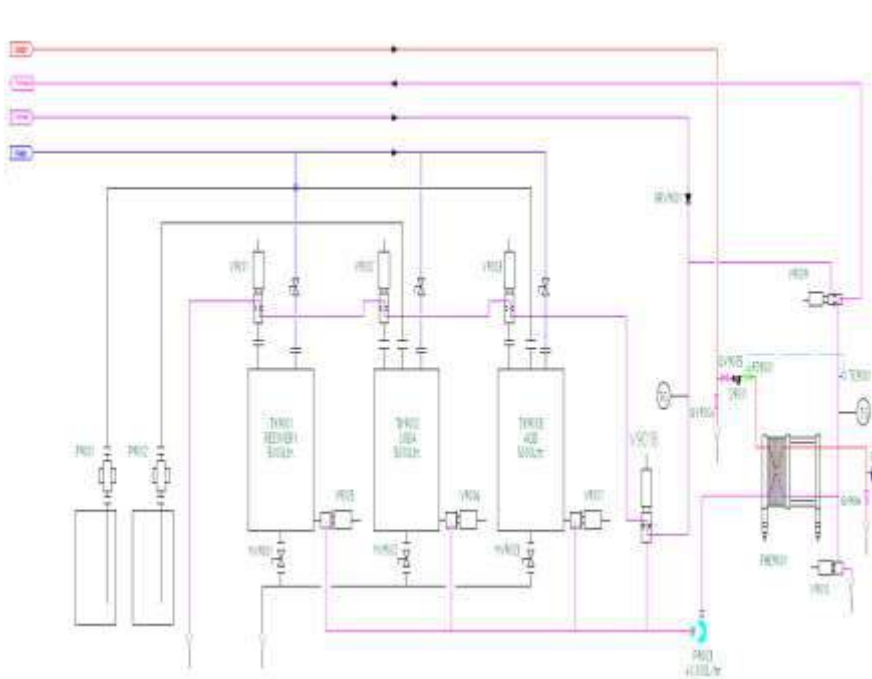
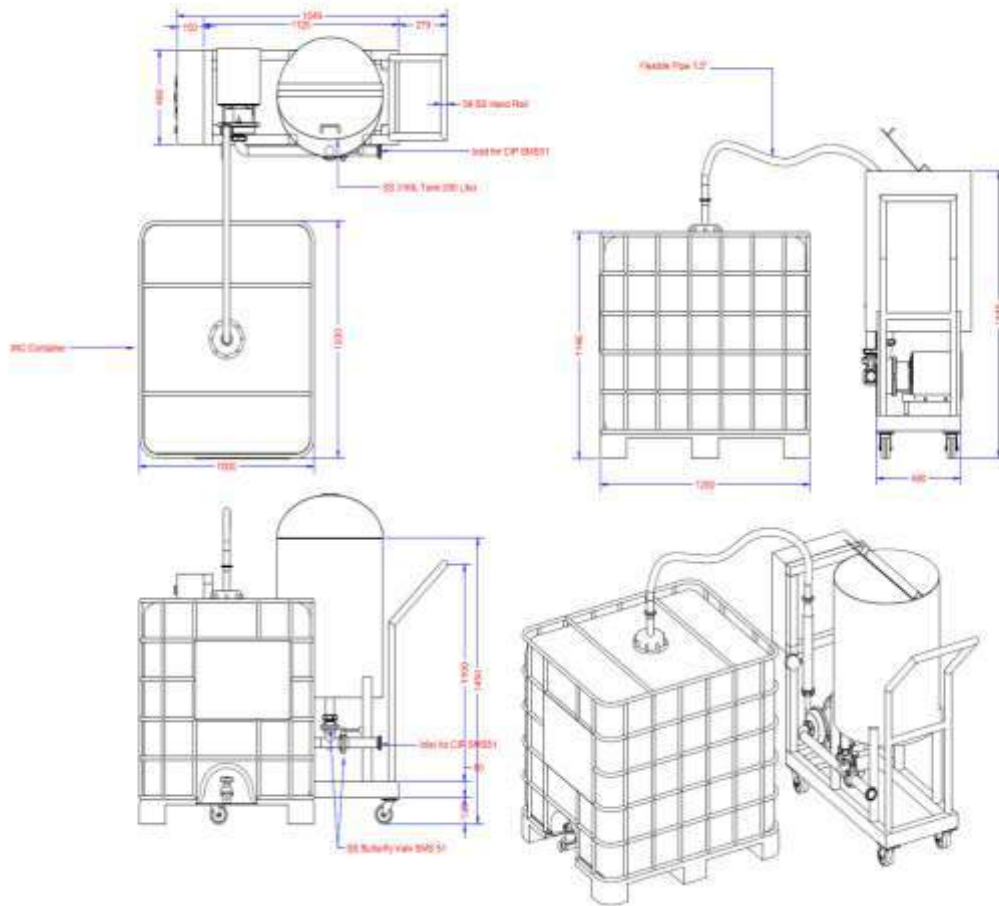

## **Stainless Steel, Platforms, Stairs, Catwalks, & Handrails**

TETRA TECH designs, fabricates and installs a wide variety of stainless steel accessories for our process systems – stainless steel platforms, stairs, handrails, mezzanines and catwalks. We also design and fabricate stainless steel hygienic platforms used with our sanitary process systems.



## Skidded Modular Process Systems

**TETRA TECH** designs compact, easy-to-install modular skidded process systems that reduce labor and save time during system installation and start-up.

Our skidded modular process systems include:

- All-inclusive tanks, pumps, valves and controls that are pre-assembled on a tubular steel frame
- Factory Acceptance Testing (FAT) that is completed prior to installation
- on-site training for operation and controls
- Flexible design that will integrate into your existing equipment and allow for easy expansion

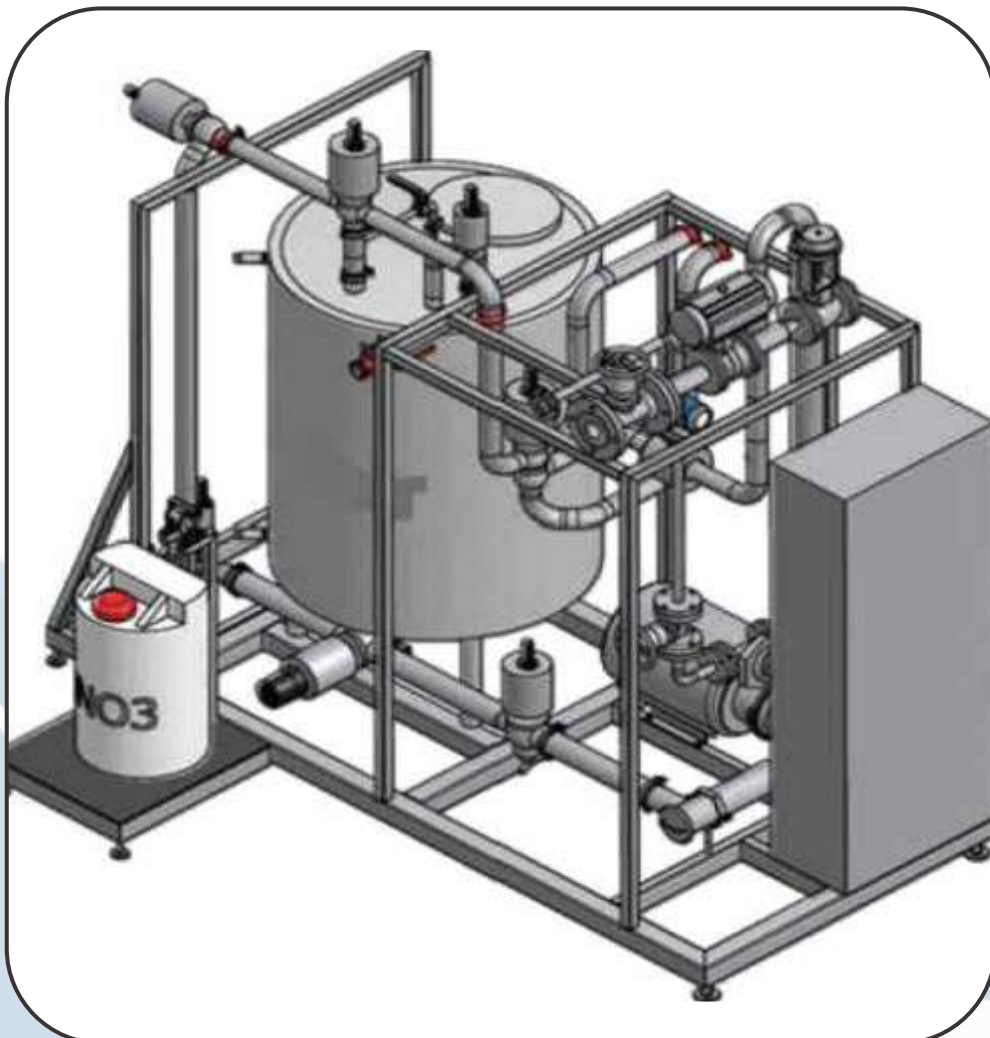



# FABRICATION DIVISION

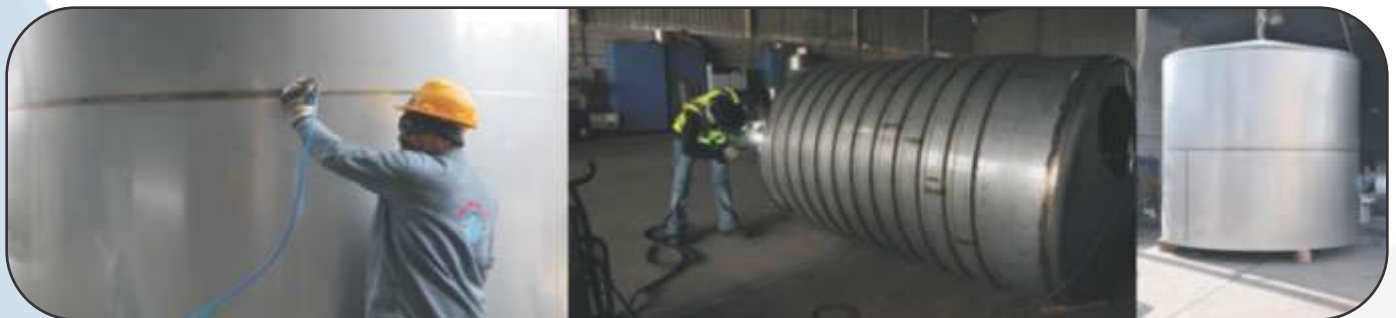

# FABRICATION DIVISION



# FABRICATION DIVISION



# FABRICATION DIVISION



# OUR GALLERY



# OUR GALLERY



# OUR SHOWROOM

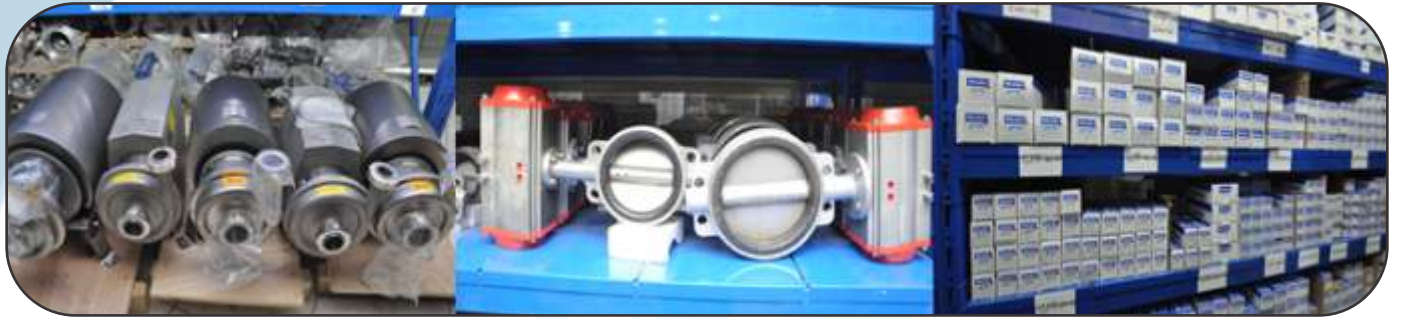

## OUR SHOWROOM





# OUR GALLERY



# OUR GALLERY



# OUR GALLERY



# OUR GALLERY



## OUR GALLERY



# OUR GALLERY





# Tetra Tech

## REGIONAL BRANCHES

<b>RIYADH</b>	Tel: +966 11 276 6604	Fax: +966 11 276 5554	Info@tetrattech.com.sa	www.tetrattech.com.sa
<b>JEDDAH</b>	Tel: +966 12 608 2087	Fax: +966 12 608 1281	sales.jed@tetrattech.com.sa	www.tetrattech.com.sa
<b>AL-KHOBAR</b>	Tel: +966 13 835 3978	Fax: +966 13 881 0994	Info@tetrattech.com.sa	www.tetrattech.com.sa
<b>DUBAI</b>	Tel: +971 4 347 3426	Fax: +971 4 347 3427	sales.uae@tetrattech.com.sa	www.tetrattech.com.sa
<b>LAHORE - PAK</b>	Tel: +92 42 38106868-70	Fax: +92 42 38106871	info@tetrattech.com.pk	www.tetrattech.com.pk
<b>SINGAPORE</b>	Tel: +65 96553605	Fax: +966 11 276 5554	Info.sg@tetrattech.com.sa	www.tetrattech.com.sa